

(C) COPYRIGHT 1998-2008 By Applied Digital, Inc.

The information in this manual is believed to be correct. However, Applied Digital, Inc. assumes no responsibility for any errors herein. This information is subject to change without notice, and should not be construed as a commitment by Applied Digital, Inc.

WARRANTY

This product is warranted against defective materials and workmanship for a period of two years from date of purchase. In the event the product fails to perform, it may be returned; Shipping Paid, to the factory to be serviced or replaced at the factory's discretion. Applied Digital, Inc. will pay to ship the repaired or replaced product by the shipping means of our choosing. Returns will not be accepted without a Return Authorization Number assigned by the factory.

It is a Condition of Sale that the user of Applied Digital Inc.'s products assumes all risk and responsibility of use and indemnifies Applied Digital, Inc. against all damages. Applied digital, Inc. is not liable for loss of profits, lost savings, special, incidental, consequential, indirect or other similar damages arising from breach of warranty, breach of contract, negligence, or other legal action even if Applied Digital, Inc. or its agent has been advised of the possibility of such damages, or for any claim brought against you by another party. This warranty allocates risks of product failure between the Purchaser and Applied Digital, Inc. Applied Digital, Inc.'s hardware pricing reflects this allocation of risk and the limitations of liability contained in this warranty.

It is a violation of the stated warranty to cut or modify the provided modular cables supplied with the T-Max® Series Timers. Connecting the T-Max® Series to third party timers not approved by Applied Digital, Inc. also violates the stated warranty. Contact your dealer or Applied Digital, Inc. if you are not sure if the timer that you are connecting is an approved timer.

Components Specifications

1, T-Max® 1A Interface Timer	Power Supply	9-12VDC or AC @ 200 mA
1, 9VDC or AC Power Supply	Dimensions	Cover Plate: 5.25" x 5.25" PCB: 2.5" x 3.75" x 1.5"
1, T-Max® 1A User's Guide		
1 50' Modular Cable w/RJ-22Connectors on both ends.	Relay	220V @ 5A; SPST

1. CONNECTING THE T-Max® 1A TO THE TANNING BED

See Section 2, Step 1

2. STAND ALONE OPERATION

Step 1: Connecting the T-Max® 1A to the Tanning Bed.

Important: There may be many wires visible on the tanning bed. Two of these wires are specifically used for connecting the tanning bed to an external timer. If you are not sure which two wires to use, refer to the tanning bed's manual or contact the bed's manufacturer.

Connect the two wires from the tanning bed for attaching to an external timer to the "Contact" screw terminal on the back of the T-Max 1A. Connect the 9V transformer to the J4 power terminal block on the back of the T-Max 1A. Plug the transformer into a 110VAC outlet.

Step 2: Applying Power to the T-Max® 1A:

- 1) Connect the 9V power supply to the "J4-12VAC" screw terminal on the back of the T-Max 1A.
- 2) Plug the power supply into a Standard 110VAC outlet

Step 3: Setting the Address:

1) Apply power to the T-Max 1A. A “99” will be displayed and an alarm will sound.

2) Press the Start/Stop button. An “88” will flash and the alarm will turn off.

3) Press the Set button. The “88” will stop flashing.

Figure 1 - Rear view of T-Max® 1A

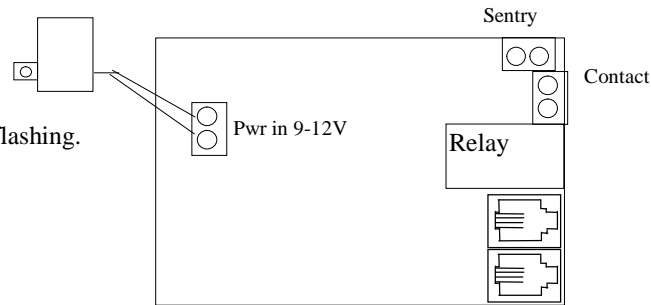
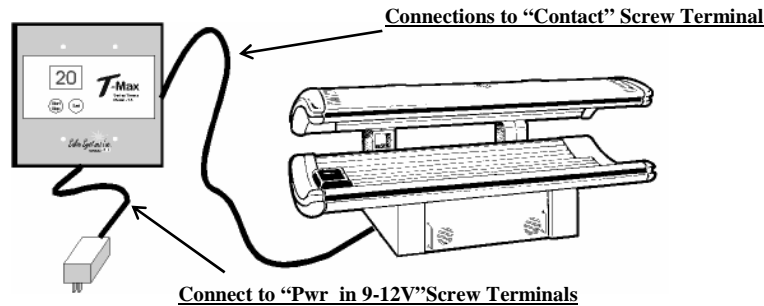

Figure 2 - Stand Alone Connections



3. REMOTE SINGLE BED CONTROL

Remote Single Bed Control is the ability to control a single tanning bed from a remote location. Two T-Max 1As are required for this configuration.

Step 1: Initial Wiring:

Follow Steps 1 and 2 in Section 2 for connecting power to the T-Max 1As and for connecting the T-Max® 1A in the tanning room to the tanning bed.

Step 2 Setting the Address:

1) Apply power to the T-Max 1A. A “99” will be displayed and an alarm will sound.

2) Press the Start/Stop button. An 88 will flash and the alarm will turn off.

3) Press the Set button. The “88” will stop flashing.

4) Remote power from the T-Max® 1A again

5) Press and hold the Start Stop button, the apply power. When a “5.2” with the period flashing appears on the display, release the Start/Stop button.

6: Press and release the Set button twice. The display will count up to “5.4”. Press the Set button once again and the display will then show a “0.0”. The period will stop flashing and stay illuminated.

7) Set the address on the T-Max® 1A at the front desk to “0.0”. Set the address on the T-Max® 1A in the tanning room to “0.1”.

8) Once the address on the T-Max® 1A at the front desk is set to “0.0” and the address on the T-Max® 1A in the tanning room is set to “0.1”, press the Start/Stop button. The T-Max® 1A in the tanning room will go to “0”. The display on the T-Max® 1A at the front desk will not change.

Step 3- Connecting the Modular Cable

A 50' modular cable was supplied with each T-Max 1A. Run one of these cables between the two T-Max 1As. Connect the modular cable to each T-Max 1A. The display on the T-Max® 1A at the front desk will then show a “0”.

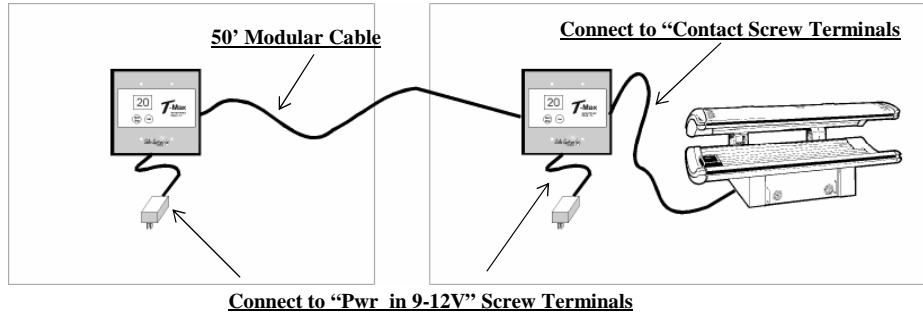

4. System Operation:

Note : If you are using two T-Max 1As in a Remote Single Bed Operation, Delay and Session Times are controlled by the T-Max® 1A at the front desk. You cannot change time from the T-Max® 1A in the tanning room.

Setting the Delay

- 1) Remote power from the T-Max 1A, press and hold the Set button, and apply power to the T-Max 1A. As soon as you see a number, period, number (i.e. 0.3), release the button.
- 2) Press the Set button until the desired delay time is displayed. 10 minutes is the maximum delay.
- 3) Press the Start Stop button. The display will then show a “0”.

Starting a Session

- 1) Press the Set button on the T-Max® 1A until the desired session in minutes is displayed.
- 2) Press the Start/Stop button. If a delay time other than 0 was set, that time will show on the T-Max® 1A and a period will be flashing rapidly on the lower right corner of the display. To eclipse the delay time, press the Start/Stop button on the T-Max® 1A in the tanning room. The tanning bed will then energize, the session time will then be displayed and the period will flash at a once per second rate. If the Start/Stop button is not pressed, the bed will automatically come on after the delay time expires.

Pausing a Session

Press and release the Start/Stop button on the T-Max® 1A in the tanning room. The period will stop flashing and stay illuminated, The session time continue to count down. To resume the session, press the Start/Stop button again. The bed will energize and the period will start flashing.

Canceling a Session

Stand Alone Operation: Press the Start/Stop button to pause the session, then press the Set button.

Remote Single Bed Operation: Press the Start/Stop and Set buttons on the T-Max® 1A at the front desk at the same time.

Clean Room:

After a session ends, two periods with no number will be displayed. To clear the clean room indication, press and hold the Set button on the T-Max® 1A in the tanning room until a “0” appears.

Bulb Hours

Note: If you are using a T-Max® 1A in a Remote Single Bed Operation, the T-Max® 1A at the front desk must not have power applied to it.

1) Press and hold both the Start/Stop and Set buttons on the T-Max® 1A in the tanning room at the same time.

Two series of numbers followed by a pause will displayed. These two numbers together are the bulb hours. IE: if the display shows a 73,58 pause, 73, 58 pause, the total bulb hours are 5873.

2) To clear the bulb hours, cycle power to the T-Max® 1A while pressing both the Start/Stop and Set buttons on the T-Max® 1A in the tanning room.

Connecting a Remote Push Button to the T-Max® 1A

A remote push button can be connected to the T-Max® 1A.

Connect the wires from your external push button circuit to the “EXT SART” Screw terminals on the back of the T-Max® 1A.

When the external push button is pressed, 5 or 24 VAC must be applied to the Ext. Start screw terminals on the back of T-Max® 1A. If you are providing 24V, remove jumper J1.

To start a session, press the Set button on the T-Max 1A to set the time, then when ready, press the Remote push button instead of the Start/Stop button on the T-Max® 1A.

Example of an External Push Button Circuit

